



Digital Direction Finder R&S DDF 195

0.5 MHz to 3 GHz

- ◆ Direction finding of signals with any modulation
- ◆ Wide-aperture behaviour above 300 MHz
- ◆ Very short signals of 10 ms detectable
- ◆ High accuracy and sensitivity
- ◆ Bandwidth setting independent of receiver
- ◆ AC supply or battery operation
- ◆ Simultaneous operation of all DF antennas (HF and VHF/UHF) without replacing antennas



ROHDE & SCHWARZ

Design

The Digital Direction Finder R&S DDF 195 may comprise the following elements:

- ◆ HF DF Antenna R&S ADD 119 (0.5 MHz to 30 MHz)
- ◆ VHF/UHF DF Antenna R&S ADD 195 (20 MHz to 1300 MHz)
- ◆ UHF DF Antenna R&S ADD071 (1.3 GHz to 3 GHz)
- ◆ DF Processor R&S EBD 195
- ◆ Cable Set R&S DDF 190Z

Moreover, a monitoring receiver with unregulated IF output of 10.7 MHz or 21.4 MHz (e.g. R&S EB200, R&S ESMB or R&S ESMC) is required.

Characteristics and operation

The Digital Direction Finder R&S DDF 195 can be operated in accordance with two DF methods using digital signal processing: the tried and tested Watson-Watt method (HF band) and the advanced correlative interferometer method (VHF/UHF band). In the latter case, the complex antenna voltages of the signal received are compared with stored reference values and then checked for maximum

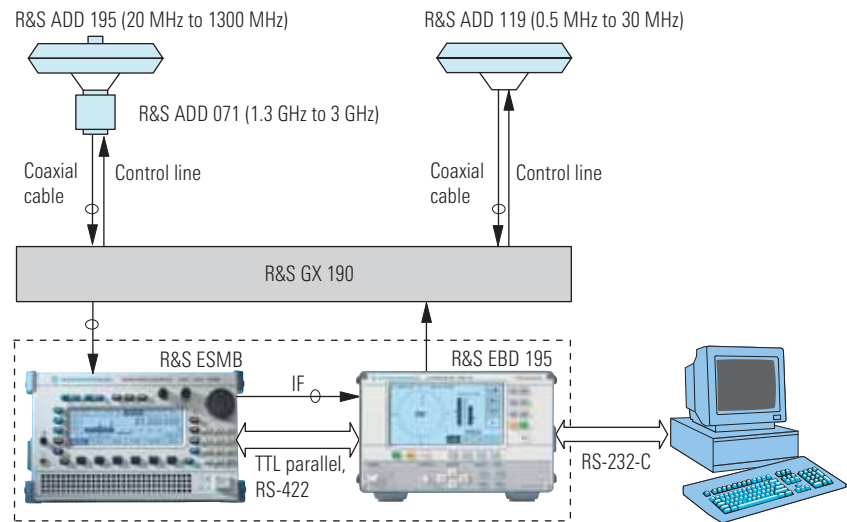

correlation. This DF method enables the implementation of wide-aperture DF antennas comprising only a few antenna elements and covering wide frequency ranges without division into subranges.

The system allows direction finding of signals with any modulation.

Three operating modes can be selected on the DF processor:

NORMAL

In this mode, which is preferably used for monitoring radio networks, the DF process is started and stopped by the squelch of the DF processor. The bearing display follows the various directions of incidence of the signals without any delay.

GATE

This mode is used for direction finding of transmitters whose emissions are interrupted briefly by modulation (e.g. keyed transmitters) if the transmitter on-the-air time is too short for the NORMAL operating mode.

CONT

In this mode, direction finding is performed continuously so that a bearing may be obtained even for specially modulated or very weak signals for which the DF process is not triggered by the squelch.

In each of these modes, bearings can also be displayed in a histogram, which is of advantage in the analysis of communication networks.

Histograms display the current bearing in digital form

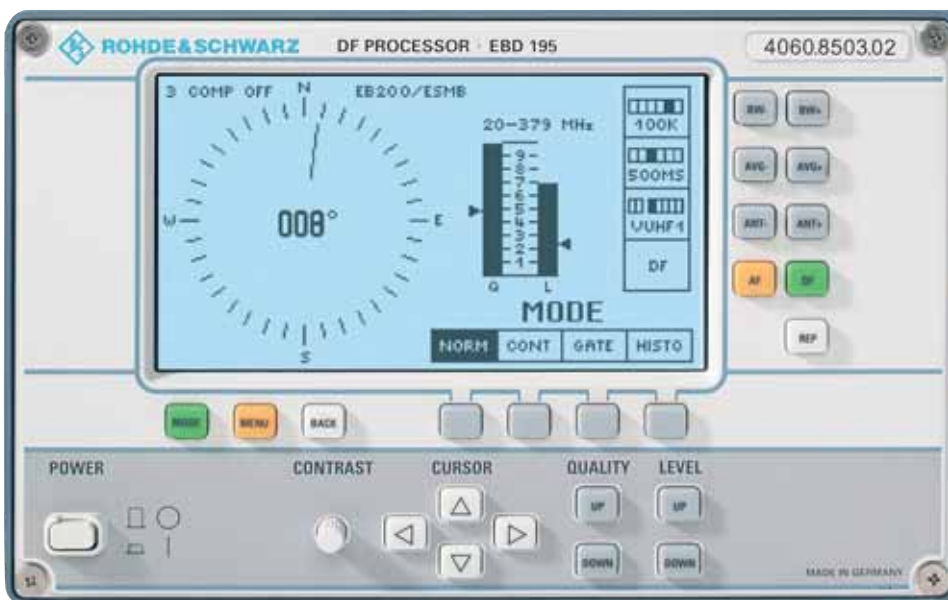



Antenna R&S ADD119 in mobile use

(three-digit number), and all values obtained since the activation of this display mode are shown as radial beams indicating the direction of incidence. The lengths of the beams are a measure of frequency occurrence of the bearings. Results can be output as lists.

The display mode can also be switched to QDM (heading with reference to magnetic north).

In the NORMAL mode, the indication disappears as soon as reception of the DF'd transmitter is over. In the other operating modes, the DF process is terminated by the user. The bearing determined last is stored and can be recalled at a keystroke. It is, however, overwritten by the next bearing value.

Evaluation according to the correlative interferometer principle plus the DF quality factor Q provide reliable information about interference in the incoming wave field. The built-in quality filter ensures that all bearings with a quality value below a settable quality threshold are suppressed. Reliable DF results can thus be obtained even in mobile operation in built-up areas.

Upon system initialization, the DF antenna system can be electronically oriented to north, so that there are no restrictions to be observed for mechanical setup of the antenna.

The scanning noise caused by the DF process in single-receiver direction finders can be switched off for monitoring purposes by interrupting the DF process (DF/AF switchover).

Several test routines are integrated in the direction finder, which can be powered either from the AC supply or a battery.

Interfaces

The digital direction finder can be remote-controlled via a serial RS-232-C interface. If the receiver is provided with a serial interface (RS-232-C, RS-422), it can be connected to a second interface on the DF processor and also remote-controlled via the remote interface of the DF processor. In addition, the direction finder is fitted with a parallel TTL interface for automatic selection of the antenna subranges from the receiver.

DF antennas

For the R&S DDF195, three DF antennas are available for mobile and stationary applications covering the frequency ranges 0.5 MHz to 30 MHz (R&S ADD 119), 20 MHz to 1300 MHz (R&S ADD 195) and 1.3 GHz to 3 GHz (R&S ADD071).

The antenna cables come in various lengths, and in various types to match the frequency range up to 1300 MHz or 3 GHz. Cables of more than 40 m in length require the Power Supply R&S IN061, which is automatically supplied with the cable set when cables of this length are ordered.

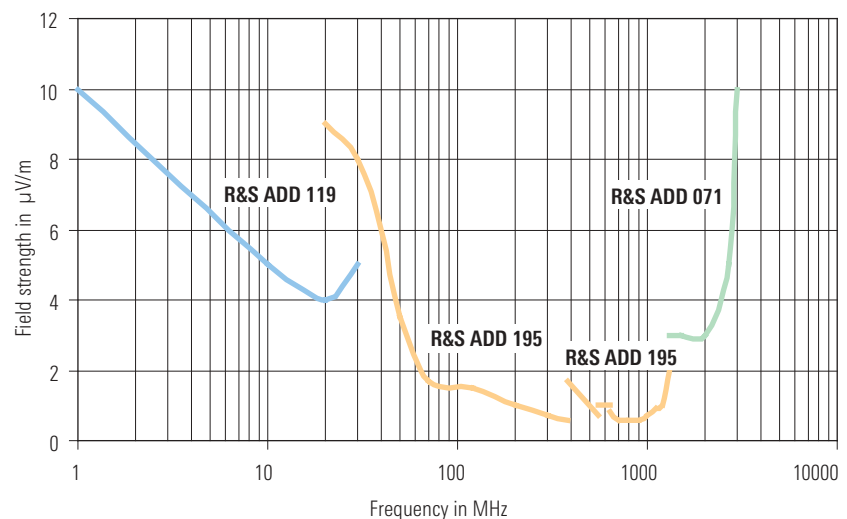

Typical sensitivity of the R&S DDF195 with Rohde & Schwarz receiver: <math><5^\circ</math> RMS bearing fluctuation, 1 kHz bandwidth (250 Hz for R&S ADD119), 5 s averaging time

Antenna accessories

If the R&S DDF 195 is operated only with the R&S ADD 119 in the shortwave range, or with the R&S ADD 195/R&S ADD071 in the VHF/UHF range, the connections between the DF Antenna R&S ADD 119 and the DF processor are straightforward (Cable Set R&S DDF190Z consisting of one RF cable, one control cable and, if necessary, Power Supply R&S IN061). Where the DF Antennas R&S ADD 119 and R&S ADD 195 and/or R&S ADD071 are to be used simultaneously, the Connection Board R&S GX 190 is needed, since the R&S EBD 195 has only one control output and each receiver only one RF input. The connection board performs frequency-dependent, automatic switch-over to the DF antenna required and allows up to three communication receiving antennas to be connected to the receiver input. Switchover is made via the DF/AF keys on the R&S EBD 195.

Where it is not possible to mount all DF antennas at the top of the mast, the DF Antenna R&S ADD 119 must be fitted on a bracket on the side of the mast. This asymmetrical installation leads to bearing errors, which can however be kept low by fitting a second R&S ADD 119 on the opposite side of the mast. The signals from the two antennas are taken to the Combiner R&S GX 119 and then to the DF equipment.

An Electronic Compass R&S GH 150 can be connected to each antenna, if desired, so that direction finding referred to north is possible at any time irrespective of the mechanical alignment of the antennas.

Various adapters are available for the DF antennas allowing stationary installation on a mast or mobile installation on a vehicle/shelter, for example.



Antennas R&S ADD 195 (top) and R&S ADD 071

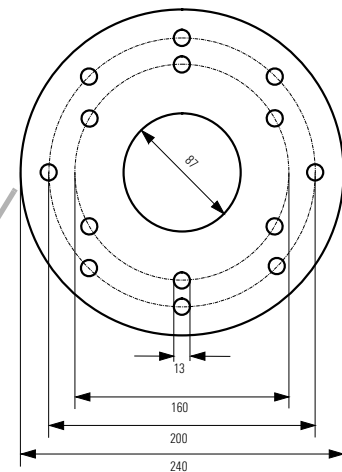

Flange dimensions

Specifications

DF method	Watson-Watt or correlative interferometer
Frequency range (depending on receiver/DF antenna)	
HF	0.5 MHz to 30 MHz
VHF/UHF	20 MHz to 1300 MHz
UHF	1.3 GHz to 3 GHz
Polarization	vertical
DF accuracy in reflection-free environment ¹⁾	2° RMS (0.5 MHz to 30 MHz) 2° RMS (20 MHz to 80 MHz) 1° RMS (80 MHz to 1300 MHz) 2° RMS (1.3 GHz to 3 GHz)
Resolution of A/D converter	16 bit
Minimum signal duration	10 ms
DF sensitivity (≤5° RMS fluctuation, 5 s averaging time, 1 kHz bandwidth, Rohde & Schwarz receiver)	
HF	10 μV/m to 4 μV/m typ. (frequency- dependent, see diagram on page 3)
VHF/UHF	1 μV/m to 9 μV/m typ. (frequency- dependent, see diagram on page 3)
UHF	3 μV/m to 10 μV/m typ.
Bandwidths	
VHF/UHF	1 kHz, 2.5 kHz, 8 kHz, 15 kHz, 100 kHz
HF	250 Hz, 500 Hz, 1 kHz, 3 kHz, 5 kHz
Averaging time	100 ms to 5 s

¹⁾ For slim masts with a height between 4 m and 8 m, the specified values may be exceeded in the frequency range between 20 MHz and 40 MHz (by 1° to 2°, depending on the mast symmetry and the ground connections at the mast base) because of the self-resonance of the mast that may occur.

Squelch for level and quality IF input	internally or externally selectable 10.7 MHz or 21.4 MHz, 50 Ω, level <0 dBm unregulated (i.e. without AGC), broadband or narrowband
DF display	graphic LCD on front panel; three-digit display with additional indication of direction on compass rose
Data interface	RS-232-C for remote control of system, 2nd serial interface and parallel inter- face for receiver control

Ordering information

Digital Direction Finder	R&S DDF195	
0.5 MHz to 30 MHz		4061.8007.02
20 MHz to 1300 MHz		4061.8007.03
20 MHz to 3000 MHz		4061.8007.04
Antenna Cable Set (various lengths)	R&S DDF 190Z	
0.5 MHz to 1300 MHz		4046.4104.xx
20 MHz to 3000 MHz		4045.1301.xx
Connection Board	R&S GX 190	4032.1508.02
Combiner	R&S GX 119	4032.1008.02
Electronic Compass	R&S GH 150	4041.8501.02
Mast adapter		on request
Remote-control software		on request

DF Processor R&S EBD195 and Monitoring Receiver R&S ESMB



General data	DF Processor R&S EBD195	Antenna R&S ADD119	Antenna R&S ADD195	Antenna R&S ADD071
Operating temperature range	-10°C to +55°C	-40°C to +65°C to MIL-STD-810E Meth. 501.3 and 502.3		
Storage temperature range	-40°C to +70°C	-40°C to +85°C to MIL-STD-810E Meth. 501.3 and 502.3		
Permissible humidity	to DIN IEC68-2-30, max. 95% cyclic, 25°C/55°C			
Mechanical resistance				
Vibration, sinusoidal	to DIN IEC68-2-6 (MIL-T-28800D), 5 Hz to 55 Hz, 0.15 mm amplitude			
Vibration, random	to DIN IEC68-2-36, 10 Hz to 500 Hz, 1.9 g (rms)			
Shock	to DIN IEC68-2-27 (MIL-STD-810D, MIL-T-28800 D), 40 g shock spectrum			
Class of protection	–	IP 55 to DIN 40050		
Immunity to salt fog to sand and dust	–	to MIL-STD-810E Meth. 509.3 to MIL-STD-810E Meth. 510.3		
Lightning protection	–	against nearby lightning strokes	against direct lightning strokes to IEC1024-1 class of protection IV (I = 100 kA, di/dt = 100 kA/ms)	
Electromagnetic compatibility	EN50081-1, EN50082-2, EN55022 class B			
Power supply	AC: 100/120/230/240 V, -12/+10%, 47 Hz to 440 Hz, overvoltage-protected to VDE 160, ≤40 VA; DC: 10 V to 32 V, ≤20 W	15 V to 18 V DC, max. 2 A from DF Processor R&S EBD 195 for cable lengths <40 m. For cable lengths >40 m, power supply is via R&S IN 061 (supplied with cable set).		
Dimensions (W x H x D)	219 mm x 147 mm x 460 mm	1.1 m dia., height 0.22 m	1.1 m dia., height 0.26 m (with lightning rod 1.26 m)	0.3 m dia., height 0.5 m
Weight	approx. 10 kg	approx. 25 kg	approx. 30 kg (incl. lightning rod)	approx. 12 kg
Max. wind speed	–	200 km/h (without ice deposit) 162 km/h (with 3 cm radial ice deposit) (to DIN4131 zone IV)		

